

1807 BAKER WAY KELSO WA 98626

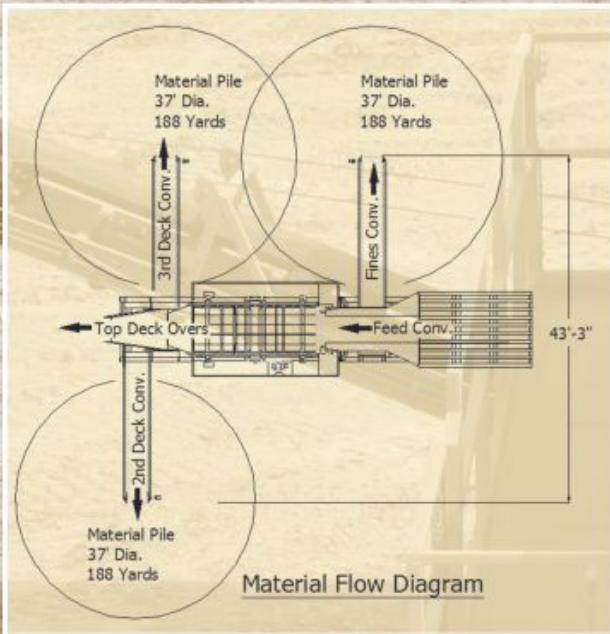

PHONE: (360) 577-7213 FAX: (360) 425-6985

# RDO 616 SCREENER (3 DECK)



### Travel Specifications

Weight At Pin	14,340 lbs.
Weight At Front Axle	11,950 lbs.
Weight At Mid Axle	14,670 lbs.
Weight At Rear Axle	17,480 lbs.
Total weight	58,440 lbs.
Height	13'-6"
Width	11'-11"
Length	54'

### Diesel Engine

Manufacturer	Caterpillar
Model	C6.6
E.P.A.	Tier 3 Certified ( Tier 4 available )
Turbo	Turbocharged Aftercooled
Horsepower	173hp @ 2200 rpm
Radiator	Upgraded AKG Radiator
Cooling	Water Cooled
Fuel Tank	80 Gallon

### Hydraulics

Legs	2 hydraulic Jacking Legs
Aux. Valve	For Off Board Conv. Or Opt. Grizzly Top
Hydraulic Tank	152 Gallon

### Feeder Hopper

Standard (Grizzly Ready)	Approx. 15 cu Yards
Wing Wall Hopper (Opt.)	18 Yards
Loading Height	13'-6"

### Screen - 6x16x3D Step Deck

Drive - Type	Hydraulic
Drive - Cubic Inch	7.72
Drive - RPM	1150
Screen Throw	5/8"
Suspension	Rubber Spring
Bearings	140mm

### Feeder / Grizzly Options

14' Hyd End Dump Grizzly (HEAVY DUTY)

### Misc. Options

Single Shaft Soil Shredder

### Leg Options

2 Or 4 Rear Hydraulic Legs

### Screen Options

Wet Kit

### Conveyor Options

Belting Options: 3-Ply, Chevron Cleating, Hot Splice

### Conveyors

	Length	Width	Motor	Cubic Inches	F.P.M.
Feed Conveyor	23'-10"	48"	Hyd	19	Vari.
Under Screen Conveyor		60"	Hyd	45	168
Fines Conveyor	16'-4"	30"	Hyd	24	314
2nd Deck Conveyor	16'-4"	30"	Hyd	45	329
3rd Deck Conveyor	16'-4"	30"	Hyd	45	329